

VITRINA REFRIGERARE „BASIA 2”

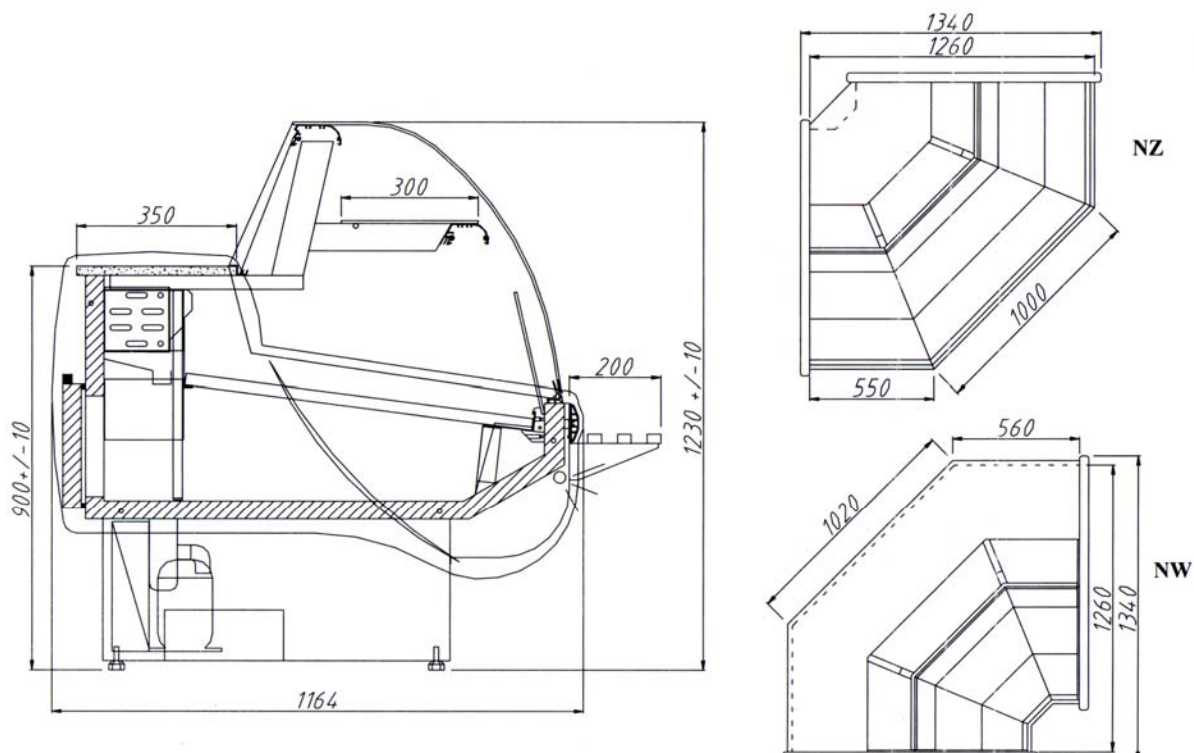

Model	2/1.1	2/1.4	2/1.7	2/2.1	2/2.5	2/NW	2/NZ
Lungime (mm)	1030	1380	1680	2010	2550	1340/1340	
Inaltime (mm)	1200 ±10	1200 ±10	1200 ±10	1200 ±10	1200 ±10	1200 ±10	1200 ±10
Adincime (mm)	1165	1165	1165	1165	1165	1165	1165
Incarcatura maxima pe 1 tava (kg)	17	17	17	17	17	17	17
Suprafata de expunere racita (m ²)	0.8	1.0	1.2	1.5	1.9	0.9	1.1
Volumul net (dm ³)	190	250	310	375	480	150	50
Voltajul 230V/50Hz	•	•	•	•	•	•	•
Puterea totala (W)	300	400	500	600	600	300	300
Puterea instalatiei de iluminare (W)	18	30	36	58	60	15	18
Consumul de curent electric (kWh/24h)	3.0	4.0	5.1	6.1	6.1	3.0	3.0
Intervalul de temperatura (°C)	+2 +8	+2 +8	+2 +8	+2 +8	+2 +8	+2 +8	+2 +8
Agentul frigorific	R 134A	R 134A	R 134A	R 134A	R 134A	R 134A	R 134A
Varianta standard							
Racire statica	•	•	•	•	•	•	•
Racire dinamica (ventilata)							•
Geam frontal curb	•	•	•	•	•	•	•
Priza aditionala pentru 230V/50Hz	•	•	•	•	•	•	•
Dezghetare automata	•	•	•	•	•	•	•
Bara de protectie frontala	•	•	•	•	•	•	•
Blat de lucru din granit	•	•	•	•	•	•	•
Optional							
Modularitate	•	•	•	•	•	•	•
Agregat extern	•	•	•	•	•	•	•
Panou frontal iluminat	•	•	•	•	•	•	•
Partea din spate realizata din inox	•	•	•	•	•	•	•
Racire dinamica (ventilata)	•	•	•	•	•	•	•
Echipeare cu tavi pentru peste	•	•	•	•	•	•	•
Echipeamente aditionale							
Raft extern pentru clienti	•	•	•	•	•	•	•
Polita interioara din sticla	•	•	•	•	•	•	•
Pereti despartitori din sticla	•	•	•	•	•	•	•

Toate echipamentele sunt concepute pentru a functiona intr-un mediu ambiental cu o temperatura de pana la 25 °C si o umiditate relativa in atmosfera de max 60%. Aceste specificatii pot fi schimbate fara o notificare prealabila.